

# MUFFLERS



## New line fits most .20-.61 engines !

- value priced
- one piece construction
- will not unbolt or come apart
- lightweight: up to 50% less than stock mufflers
- MACS design, less likely to be damaged in a crash
- ready for MACS NEW Smoke System (order #9521 - \$29.95)

**MUFFLES !  
PERFORMS !**



SIZE	ENGINES FITTED	PRICE	STOCK NUMBER
<b>.25-.36</b>	O.S. .21-.32 FSR, .25 FX, .32 SX + THUNDER TIGER .25 PRO & .36 PRO + MDS .28-.38 FS PRO ENYA .21 CX & SS + MAGNUM .25 PRO & .28 PRO + WEBRA .28 SPEED	<b>27.95</b>	6340
	O.S. .25 FP, S.T.G. .34		6300
<b>.40-.47</b>	.40 SIZE ADAPTER MUFFLER (requires adapter plate - order from list below)	<b>29.95</b>	6400
	<b>MULTI-ENGINE STRAP-ON FITS:</b> O.S. .30-.35-.40 RC old strap-on series ENYA .29-.35-.40-.45 old strap-on series + K&B .40 old strap-on (K&B also requires plugs #9520 below)		6520
	O.S. .40-.46 FX, O.S. .40-.46 SF + THUNDER TIGER .40 & .46 PRO ASP .46 + GMS 2000 .40-.47 + MECOA .40-.46 + MDS .48 FS PRO (bolt-through)		6590
	S.T.G. .40-.45 (bolt-through)		6620
	O.S. .35-.40 FP, O.S. .40-.46 LA + THUNDER TIGER .42 - .46 GP MAGNUM .40 & .44 GP + WEBRA .40 RC		6650
<b>.60 - .61</b>	.60 SIZE ADAPTER MUFFLER (requires adapter plate - order from list below)	<b>32.95</b>	6700
	O.S. .60 FP, .61 SF, .61 FX + THUNDER TIGER .61 GP, .61 PRO + MAGNUM .61 PRO + MDS .68 FS PRO		6860
	S.T.G. .61-.75 (bolt-through)		6900
	S.T.S. .61K (bolt-on)		6920
Engine Plugs - for use with strap-on muffler #6520 on K&B .40 old strap-on motor - Set of 2		<b>.99</b>	9520

### MUFFLER ADAPTER PLATES

To be used with adapter mufflers (#6400 or #6700) listed above

.40 SIZE ADAPTER PLATE (use with #6400 adapter muffler)	PRICE	STOCK NUMBER	.60 SIZE ADAPTER PLATE (use with #6700 adapter muffler)	PRICE	STOCK NUMBER
ENYA .40X & CX	<b>7.95</b>	6428	ENYA .45-50SS	<b>8.95</b>	6718
ENYA .40 SS		6438	IRVINE .61, FOX .60-.74		6758
MDS .40 FS (bolt-on)		6488	K&B .61		6778
H.B. .40 (bolt-through)		6498	K&B .65 SPORTSTER		6788
MDS .46 FS (bolt-through) (old style)		6518	Y.S. .61 Long Stroke, KRAFT .61, RJL .61		6808
K&B .40		6538	MOKI .61		6818
K&B .45 SPORTSTER		6548	MDS .61 FS (bolt-on) (old style)		6838
MVVS .40		6558	O.S. .50-.61 FSR, ASP .61, ENYA .61X, MVVS .61, WEBRA .61 (bolt-on)		6858
O.S. .40 FSR, ASP .40, IRVINE .40, ROYAL .40-.45		6588	O.S. .60 FP, .61 SF, .61 FX, TT .61 GP & PRO, MDS .58		6868
O.S. .40-.46 FX, .40-.46 SF, TT .40-.46 PRO, MDS .48		6598	ROSSI .61 (new 4mm screws)		6878
ROSSI .40-.45		6608	S.T. X .61 (bolt-on), MOKI 8.5		6918
S.T. G .40-.45 (bolt through)		6628	Y.S. .60 (standard stroke)		6938
S.T. .40-.46 K (bolt-on)		6638	PICCO .61		<b>17.95</b> 6888
O.S. .35-.40FP, .40-.46LA, TT.42-.46 GP, MAG .40-.46 GP		6658			
WEBRA .40 SPEED (bolt-through)		6648			
Y.S. .45	6678				
PICCO .40-.45	<b>16.95</b>	6618			

## PUMPLESS SMOKE SYSTEM



- EFFECTIVE PUMPLESS SYSTEM
- High temperature ALL METAL check valve
- Easy installation - Great performance with MACS MUFFLER
- MACS MUFFLER even has pressure tap holes spot-drilled
- NO GUESSWORK !
- Also for use with most mufflers

#9521... \$29.95

# AERO TUNED PIPES

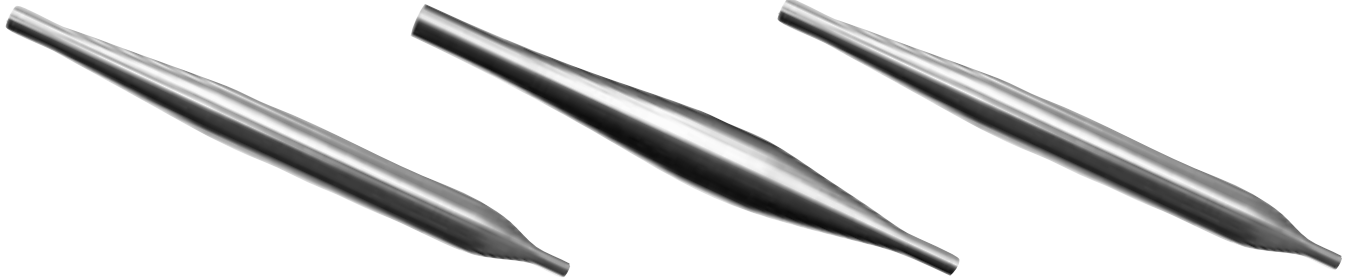

QUIET PIPE			TUNED PIPE			MUFFLED TUNED PIPE		
SIZE	PRICE	STOCK NUMBER	SIZE	PRICE	STOCK NUMBER	SIZE	PRICE	STOCK NUMBER
			2.5cc (.10-.15)	26.95	1110	2.5cc (.10-.15)	38.95	1210
3.5cc (.20-.38)	44.95	1020	3.5cc (.20-.38)	27.95	1120	3.5cc (.20-.38)	39.95	1220
			6.5cc (.35-.45)	32.95	1130	6.5cc (.35-.45)	44.95	1230
7.5cc (.40-.50)	53.95	1040	7.5cc (.40-.50)	33.95	1140	7.5cc (.40-.50)	45.95	1240
8.5cc (.45-.60)	61.95	1050	8.5cc (.45-.60)	37.95	1150	8.5cc (.45-.60)	52.95	1250
10cc (.60-.75)	62.95	1060	10cc (.60-.75)	38.95	1160	10cc (.60-.75)	53.95	1260
10cc (.60-.75) long-stroke	64.95	1062						
15cc (.90-1.2)	79.95	1090	15cc (.90-1.08)	42.95	1190	15cc (.90-1.08)	58.95	1290
20cc (1.0-1.5) long-stroke-F3A	89.95	1092						
25cc (1.2-1.7)	104.95	1095	25cc (1.2-1.7)	69.95	1195			
35cc (1.5-3.2)	112.95	1096	35cc (1.5-3.2)	70.95	1196			
60cc (3.2-4.8)	130.95	1097	60cc (3.2-4.8)	75.95	1197			

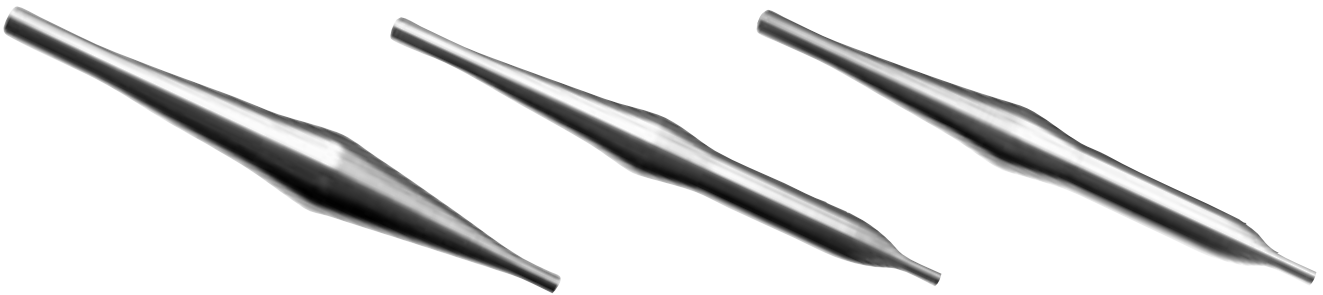

TUNED PIPE (NITRO PIPE)			MUFFLED TUNED PIPE			QUIET PIPE		
SIZE	PRICE	STOCK NUMBER	SIZE	PRICE	STOCK NUMBER	SIZE	PRICE	STOCK NUMBER
3.5cc (lo nitro)	32.95	1323	3.5cc (lo nitro)	43.95	1327			
3.5cc (hi nitro)	33.95	1324	3.5cc (hi nitro)	44.95	1328			
3.5cc (compound)	42.95	1325	3.5cc (compound)	53.95	1329	3.5cc (compound)	71.95	1322
7.5cc	51.95	1345	7.5cc	60.95	1349	7.5cc	82.95	1342
11cc	54.95	1365	11cc	64.95	1369	11cc	85.95	1362
13cc	59.95	1385	13cc	69.95	1389	13cc	94.95	1382
15cc	60.95	1395	15cc	70.95	1399	15cc	96.95	1392

# PRE-TUNED SYSTEM



**READY TO ATTACH TO YOUR ENGINE AND FLY - NO TUNING NECESSARY**



**HEADER - SCREWS - SILICONE CONNECTOR/TIE STRAP  
MUFFLED TUNED PIPE - MOUNTING BRACKET**

ENGINE(S) FITTED	PRICE	STOCK NUMBER	ENGINE(S) FITTED	PRICE	STOCK NUMBER
<b>.25 ENGINES</b>	<b>63.95</b>		<b>.61 ENGINES</b>	<b>80.95</b>	
O.S. .25-.32 FX, SR FSR, MAGNUM .25-.28 PRO TT PRO .25-.36, MDS .28-.38 FS PRO		1910	K & B .61		1970
S.T.G. .34 AERO (bolt through)		1913	O.S. .61 FX, TT PRO .61, MDS .68 FS PRO		1973
<b>.40-.45 ENGINES</b>	<b>70.95</b>		O.S. .61 SF (long-stroke) (non-pump),		1976
K & B .40		1930	O.S. .60 & .61 FSR		1980
MVVS .40		1933	ROSSI .60		1986
O.S. .40 FP, MAGNUM GP .40-.44, TT .42 & .46 GP		1936	S.T.S .61, COMO .61 (bolt through)		1990
O.S. .40-.45 FSR, ROYAL .40-.45, ASP .40		1940	S.T.S .61K (bolt on)		1993
O.S. .40-.46 SF, ASP .46, ROYAL .46, TT PRO .40-.46 MDS .48 FS PRO		1943			
ROSSI .40 & .45		1946			
S.T.GS .40-.45, COMO .40-.45 (bolt through)		1950			
S.T.S .40-.45K (bolt on)	1953				

# WIZARDS



SIZE	PRICE	STOCK NUMBER
3.5cc (.20-.25)	<b>35.95</b>	1820
3.5cc Ducted Fan Exhaust System (for R.K. .20 with K&B 3.5 engine)	<b>48.95</b>	1821
3.5cc Ducted Fan Exhaust System (for R.K. .20 with O.S. .25 VF DF engine)	<b>48.95</b>	1822
Sport .40	<b>38.95</b>	1835

# FOUR-CYCLE



## 4-CYCLE FLEXIBLE QUIET MUFFLER SYSTEM

This system can be purchased in two ways:

**A - As a pre-assembled system, with straight adapter**  
(unless otherwise indicated with 90° adapter)

**B - As separate items: motor adapter (straight or 90°), flexible tubing and muffler pipe**

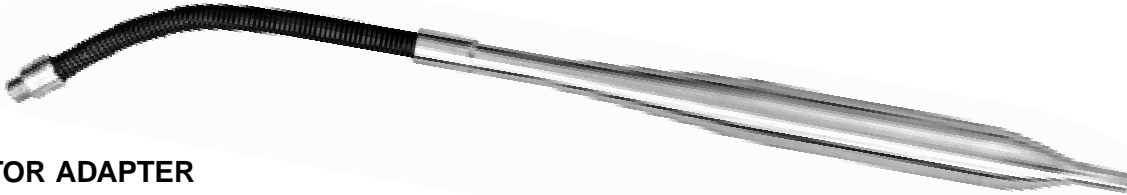

- MOTOR ADAPTER
- QUIET MUFFLER PIPE
- FLEXIBLE TUBING

### A - PRE-ASSEMBLED SYSTEM

ENGINE(S) FITTED	PRICE	STOCK NUMBER	ENGINE(S) FITTED	PRICE	STOCK NUMBER
Y.S. 120 (with 90° motor adapter included)	92.95	1689	Y.S. 91 & 120 (with straight fitting)	82.95	1693
ENYA 80 4C, O.S. 40-60 FS & SURPASS	82.95	1690	SAITO FA 120 & FA 300		1694
ENYA 90, O.S. 70 & 91 SURPASS, ASP 80, YS .53		1691	O.S. 120 SURPASS, GEMINI 240 & 300		1695
O.S. 90 FS, SAITO 65 & 90		1692	ENYA R-120 4C	92.95	1697

### MUFFLER EXTENDER (includes 1-90° muffler adapter + 1-straight muffler adapter + 1-9" flex tube)

	PRICE	STOCK NUMBER
Y.S. 91 & 120	47.95	1663
SAITO FA 120 & 300		1664

### B - PARTS LIST

SIZE	ENGINE(S) FITTED	STRAIGHT ADAPTER	NO. OF NOTCHES	PRICE	STOCK NUMBER
10 x .75	ENYA 80, O.S. 40-60 FS & SURPASS		0	15.95	1650
11 x .75	ENYA 90, O.S. 70 & 91 SURPASS, ASP 80, YS .53		1 Notch		1651
12 x 1.0	O.S. 90 FS & SAITO 65 & 90		2 Notches		1652
13 x 1.0	Y.S. .91 & 120		3 Notches		1653
14 x 1.0	SAITO FA 120 & FA 300		4 Notches		1654
14 x .75	O.S. FS 120 SURPASS		5 Notches		1655

SIZE	ENGINE(S) FITTED	90° ADAPTER	NO. OF NOTCHES	PRICE	STOCK NUMBER
10 x .75	ENYA 80, O.S. 40-60 FS & SURPASS		0	25.95	1670
11 x .75	ENYA 90, O.S. 70 & 91 SURPASS, ASP 80, YS .53		1 Notch		1671
12 x 1.0	O.S. 90 FS & SAITO 65 & 90		2 Notches		1672
13 x 1.0	Y.S. 120		3 Notches		1673
14 x 1.0	SAITO FA 120 & FA 300 (ENYA 120 4c & PREDATOR)		4 Notches		1674
14 x .75	O.S. FS 120 SURPASS		5 Notches		1675

### Adapter Plates

	PRICE	STOCK NUMBER
ENYA R120 TO 14 x 1.0 (also requires #1654 or #1674 to adapt to flex tubing)	13.95	1657

### MUFFLER PIPE

	PRICE	STOCK NUMBER
40-120 QUIET MUFFLER PIPE	62.95	1682

### FLEXIBLE TUBING

LENGTH	PRICE	STOCK NUMBER	LENGTH	PRICE	STOCK NUMBER
9"	8.45	9411	18"	12.95	9413
12"	9.45	9412	24"	15.95	9414

# HEADER PIPES



## SIDE EXHAUST ENGINES

MARINE: SAME AS STANDARD WITH 15" UPSWEEP

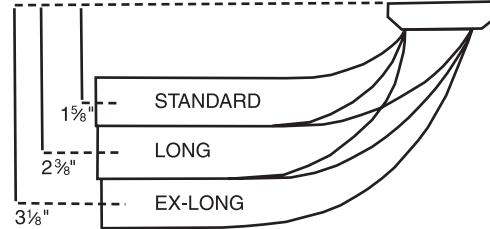
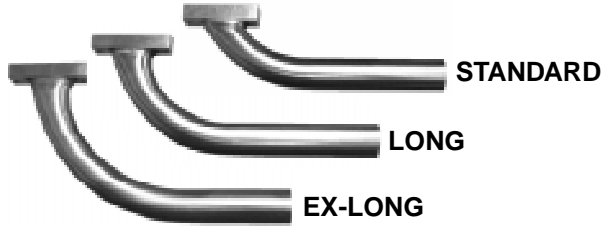

EACH HEADER IS CUSTOM FIT TO THE SPECIFIC ENGINE AND INCLUDES FLEXIBLE CONNECTOR AND TIE STRAPS

ENGINE(S) FITTED	PRICE	STOCK NUMBER				ENGINE(S) FITTED	PRICE	STOCK NUMBER				
		STD	LONG	EX-LONG	MARINE			STD	LONG	EX-LONG	MARINE	
<b>.10-.15 ENGINES</b>	19.95					<b>.50-91 ENGINES</b>	24.95					
O.S. .10 FSR, .10-.15 FP, TT GP .10-.15 MDS .18 FS PRO		2040	2041	2042	2043	ENYA .45-.50SS H.P. .61 WEBRA .61 SPEED (old strap) IRVINE .61, FOX .60 EAGLE III K & B .61, H.B. .61, WEBRA .61 BH Y.S. .61 long, KRAFT .61, RJLK .61 MOKI .60 MDS .58 FS PRO MDS .61 FS (bolt on) O.S. .50 FSR, .61 FSR ASP .61, ENYA 60X, MVVS .61-.77, WEBRA .61 SPEED (bolt on) O.S. .61 FX, SF, .60 FP (bolt through) MAGNUM .61 PRO, TT GP & PRO .61 MDS .68 FS PRO ROSSI .60 & .61, POWERHOUSE .60 S.T.G .60, S. .61-.75 COMO .61-.75 (bolt through) S.T.S .61K, .75K (bolt on) Y.S. .60 (non long-stroke)		2710	2711	2712	2713	
<b>.20-.36 ENGINES</b>	22.95											
MVVS .20		2260	2261	2262	2263	2730	2731	2732	2733			
IRVINE .20		2270	2271	2272	2273	2750	2751	2752	2753			
MDS .25 FS (bolt on)		2290	2291	2292	2293	2770	2771	2772	2773			
S.T.G .34 (bolt through)		2350	2351	2352	2353	2800	2801	2802	2803			
S.T.G. .34, MAGNUM .21-.28 GP O.S. .20-.25 FP, TT PRO .25		2300	2301	2302	2303	2810	2811	2812	2813			
O.S. .21-.32 FX & SX, ENYA .21 CX - SS30 TT PRO .25-.36, MAGNUM .25-.28 PRO WEBRA .28 SPD, MDS .28-.38 FS PRO		2340	2341	2342	2343	2820	2821	2822	2823			
S.T.S .21-.34K (bolt on)		2360	2361	2362	2363	2830	2831	2832	2833			
<b>.35-.46 ENGINES</b>		23.95										
ENYA .40 X, O.P.S. .40			2420	2421	2422	2423	2850	2851	2852	2853		
MDS .40 FS (bolt on)	2480		2481	2482	2483	2860	2861	2862	2863			
H.B. .40	2490		2491	2492	2493	2870	2871	2872	2873			
JETT .40-.46	2500		2501	2502	2503	2900	2901	2902	2903			
MDS .46 (bolt through) (old style)	2510		2511	2512	2513	2920	2921	2922	2923			
K & B .40 (bolt through)	2530		2531	2532	2533	2930	2931	2932	2933			
K & B .45 SPORTSTER	2540		2541	2542	2543							
MVVS .40	2550		2551	2552	2553							
O.S. .40-.45 FSR, ASP .40, IRVINE .40 FOX .45 & 50 BBRC (bolt on)	2580		2581	2582	2583	<b>.90-1.08 ENGINES</b>	26.95					
O.S. .40-.46 FX & SF, TT PRO .40-.46, MECOA .40-.46, GMS 2000 .40 & .47 (bolt through), ASP .46, MDS .48 FS PRO	2590	2591	2592	2593	O.S. .90-1.08 S.T.G 90 (bolt through) O.S. .91 FX	2940		2941	2942	2943		
ROSSI .40-.45, POWERHOUSE .40-.45	2600	2601	2602	2603	<b>1.2-1.5 ENGINES</b>	27.95						
S.T. GS .40-.45 COMO .40-.50 (bolt through)	2620	2621	2622	2623	IRVINE 120-150 ASP 120, MAGNUM XL 120 MOKI 130 S.T.G 2300 TT 120 PRO WEBRA 120, BULLY 1.2 PR, GMS 120 ZENOAH G-23		4050	4051	4052			
S.T.S .40-.45, COMO .40-.45 (bolt on)	2630	2631	2632	2633	<b>1.5-3.2 ENGINES</b>		30.95					
WEBRA .40-.45 SPEED (bolt through)	2640	2641	2642	2643	MOKI 1.5-1.8-2.1 S.D. 2.6-3.2 ci S.T.S. 2000-2500-3000-3250 O.S. 35K / S.T.S. 45K TARTAN & TWIN 3 W 35cc & 70-80cc TWIN ZENOAH 445 TWIN ZENOAH G-45			4230	4231	4232		
WEBRA .40RC, O.S. .40 FP, .40-.46 LA MAGNUM .40-.44 GP, TT .42 & .46 GP	2650	2651	2652	2653	<b>3.0-4.8 ENGINES (*)</b>			33.95				
WEBRA .40 SPEED (old strap)	2660	2661	2662	2663	QUADRA 52cc 3 W 60cc & 120CC TWIN ZENOAH Q G-62				4460	4461	4462	
YS .45 SF	2670	2671	2672	2673					4520	4521	4522	
						4560			4561	4562		
<b>BOLT THROUGH</b>		<b>BOLT ON</b>										

# HEADER PIPES



## REAR EXHAUST ENGINES

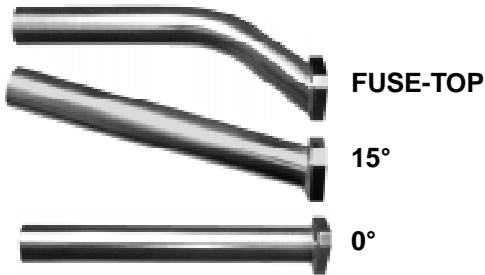

## SPECIAL APPLICATION HEADERS SIDE EXHAUST ENGINES

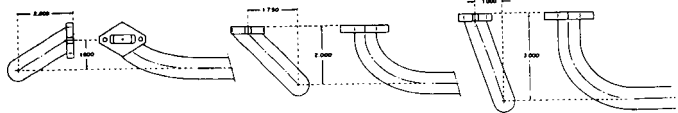

**DOWN UNDER\***      **CENTER LINE\*\***      **LONG DOWN UNDER**

\*The down under header is for use on a high wing airplane with an upright mounted engine. The pipe will be down under the wing and away from the side of the airplane.

\*\*The CENTER LINE header can be used the same as the Down Under header but with more of a drop. Or on a side mount engine it will put the pipe in the center of the airplane's belly.

ENGINE(S) FITTED	STOCK NUMBER		
	0°	15°	FUSE-TOP
<b>.15-.20 ENGINES</b>	<b>12.95</b>	<b>12.95</b>	<b>19.95</b>
RJL CONQUEST .15	3200	3201	3202
<b>.21-.34 ENGINES</b>	<b>13.95</b>	<b>13.95</b>	<b>21.95</b>
K & B 3.5, O.S. .25 VF-DF	3350	3351	3352
MVVS .20R	3370	3371	3372
<b>.40-.46 ENGINES</b>	<b>15.95</b>	<b>15.95</b>	<b>23.95</b>
K & B 6.5-7.5, IRVINE .40 RE	3450	3451	3452
MVVS .40 R	3470	3471	3472
O.P.S. .40	3480	3481	3482
O.S. .40-.46 VF + VR-M	3520	3521	3522
YS .45 RF	3570	3571	3572
<b>.60-.65 ENGINES</b>	<b>17.95</b>	<b>17.95</b>	<b>24.95</b>
ENYA .60	3590	3591	3592
K & B .67 (11cc)	3600	3601	3602
IRVINE .61 RE	3610	3611	3612
MOKI .61 R	3630	3631	3632
O.S. .61 VF, O.S. .65 VR-M	3680	3681	3682
MVVS .60-.77 R, FOX, 60R	3720	3721	3722
ROSSI .61 (for O-ring)	3760	3761	3762
S.T. X .61 (bolt on)	3780	3781	3782
WEBRA .61, OPS .60, YS .61-R (long-stroke)	3810	3811	3812
Y.S. .60R (std stroke)	3860	3861	3862
<b>.91 ENGINES</b>	<b>20.95</b>	<b>20.95</b>	<b>26.95</b>
K & B .82-1.0 (bolt on)	3880	3881	3882
O.S. .77-.91VR (bolt on)	3890	3891	3892
K & B .82-1.0 (for O-ring) ROSSI .91 R / O.S. .77-.91VR (for O-ring)	3930	3931	3932

	PRICE	DOWN UNDER	CENTER LINE	LONG DOWN UNDER	LONG CENTER LINE
KRAFT .61, YS 61 LONG	<b>26.95</b>	2804	2805	2806	2807
OS .61 FSR, ASP .61-.91		2854	2855	2856	2857
ENYA .61 X, WEBRA .61 SP (BO)		2864	2865	2866	2867
OS .61 SF (long-stroke)		2924	2925	2926	2927
S.T.S. .61 K (bolt on)					

## SPECIAL APPLICATION HEADERS REAR EXHAUST ENGINES

180°		PRICE	STOCK NUMBER	PRICE	STOCK NUMBER
O.S. .21 RZ-M	<b>26.95</b>	3365	O.S. .46 VX-M	<b>27.95</b>	3525
			K&B 6.5-7.5		3455

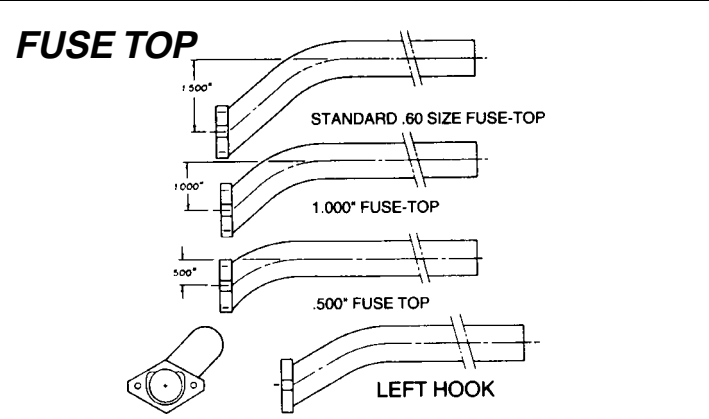

ENGINE(S) FITTED	STOCK NUMBER		
	0°	20°	FUSE-TOP
<b>1.2-1.5 ENGINES</b>	<b>21.95</b>	<b>21.95</b>	<b>27.95</b>
MOKI 120 R	4720	4721	4722
O.S. 140 RX	4740	4741	4742
TT 120 R	4760	4761	4762
WEBRA 120 LS R, UAV 1.2 LS - 1.4 SP	4780	4781	4782
<b>1.8-2.7 ENGINES</b>	<b>23.95</b>	<b>23.95</b>	<b>23.95</b>
RYOBI 31 SP	4820	4821	4822
MAGNUM II R	4840	4841	4842
QUADRA 42cc R	4860	4861	4862
ZENOAH Q G-38 R	4880	4881	4882

	PRICE	STANDARD FUSE TOP	.500" FUSE TOP	1.000" FUSE TOP	LEFT HOOK	
		24.95	25.95	25.95	25.95	
O.S. .61-.82 VF-RF		3682	3683	3684	3687	
WEBRA .61, OPS .60, YS .61-R (long-stroke)		3812	3813	3814	3817	
		STANDARD 175 FUSE TOP	.750" FUSE TOP	1.250" FUSE TOP	2.250" FUSE TOP	
		PRICE	27.95	28.95	28.95	29.95
O.S. 140 RX		4742	4743	4744	4745	
TT 120 R		4762	4763	4764	4765	
WEBRA 120 LS R, UAV 1.2 LS - 1.4 SP		4782	4783	4784	4785	

# ACCESSORIES



DESCRIPTION	PRICE	STOCK NUMBER
PRESSURE FITTING - 8-32 THREAD	1.30	9021
THIN WALL	2.60	9041
90° THIN WALL	3.75	9051
EXHAUST DIVERTER - 7/16 OD X .035 Wall	6.25	9113
1/2 OD X .035 Wall	6.25	9114
9/16 OD x .035 Wall	6.25	9115
5/8 OD x .035 Wall	6.25	9116
SILICONE HEADER PIPE CONNECTOR, 1/2" ID x 1 1/2" LONG WITH 2 CINCH STRAPS (for .10-.35 engines)	2.85	9161
SILICONE TUBING, 1/2" ID - 1 FOOT (for .35-.90 engines)	11.50	9163
1 YARD	21.95	9164
SILICONE HEADER PIPE CONNECTOR, 5/8" ID x 2" LONG WITH 2 CINCH STRAPS (for .35-.90 engines)	3.10	9171
SILICONE TUBING, 1/2" ID - 1 FOOT (for .35-.90 engines)	11.50	9173
1 YARD	21.95	9174
SILICONE HEADER PIPE CONNECTOR, 3/4" ID x 2 1/2" LONG WITH 2 CINCH STRAPS (for .91-3.2 engines)(*)	3.40	9181
SILICONE TUBING, 3/4" ID - 1 FOOT (for .91-3.2 engines)(*)	12.50	9183
1 YARD	22.95	9184
CINCH STRAPS FOR HEADER PIPE 10/PACK	1.20	9211
PIPE MOUNT KIT (for .20-3.2 engines)	2.95	9231
"O" RING, 1/2" ID (for 3.5 ducted fan system) 3/PACK	1.15	9251
ALUMINUM TUBING 9/16 OD x 6" (for .10-.15 engines)	3.00	9351
9/16 OD x 12"	4.50	9352
5/8 OD x 6" (for .20-.36 engines)	3.50	9361
5/8 OD x 12"	5.00	9362
3/4 OD x 6" (for .35-1.08 engines)	4.00	9371
3/4 OD x 12"	5.50	9372
PROPELLER HUB NUTS - (A) 1/4" x 28	4.75	9122
ALUMINUM (B) 5/16 x 28	4.75	9123
(D) 6mm x 1mm	4.75	9125
(E) 7mm x 1mm	4.75	9126
(H) 8mm x 1.25mm	4.75	9128
PROPELLER HUB NUTS - (A) 1/4" x 28	5.95	9132
BRASS (B) 5/16 x 28	5.95	9133
(D) 6mm x 1mm	5.95	9135
(E) 7mm x 1mm	5.95	9136
(H) 8mm x 1.25mm	5.95	9138

## 8/32 PRESSURE FITTING



## STRAIGHT THIN WALL PRESSURE FITTING

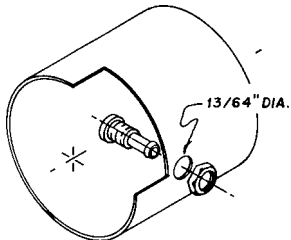

## 90° THIN WALL PRESSURE FITTING

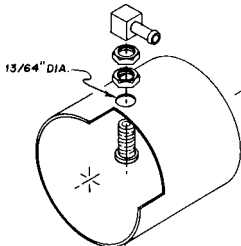

## 90° WATER FITTING

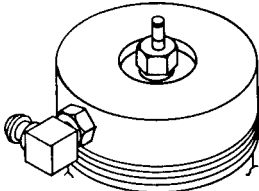

**EXHAUST DIVERTER**  
 Aluminum Exhaust Diverter.  
 Won't Burn Out!  
 Comes in 4 Sizes.

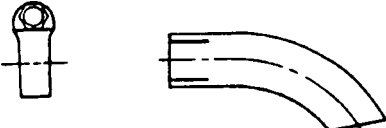

### PROPELLER HUB NUT SIZING

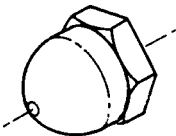

Part Number	Size
ASP .28-.46	(A)
ASP .61	(B)
ENYA .21-.60 TV	(E)
ENYA .19-.45 CX	(D)
ENYA .25-.50 SS	(A)
FOX .60-1.2	(B)
HB .21-.61	(A)
HP .21-.61	(A)
HB 1.2	(B)
IRVINE (ALL)	(A)
K & B (ALL)	(A)
OS .21-.46	(A)
OS .60-1.2	(B)
ROSSI .40-.90	(H)
ROYAL .20-.45	(A)
SAITO .60-.90	(E)
SAITO 1.2	(H)
ST .21-.45	(A)
ST .60-.90	(B)
WEBRA .28-.61	(A)
YS .45-.61	(H)

### SCREWS

SIZE	PRICE PER SET	STOCK NUMBER
<b>STANDARD</b>	.99	3/48 x 1 1/4" F.H.
4/40 x 1/2" SOC		
4/40 x 3/4" SOC		
4/40 x 1 1/4" SOC		
4/40 x 1 1/2" SOC		
5/40 x 1/2" SOC		
5/40 x 3/4" SOC		
5/40 x 1 1/4" SOC		
5/40 x 1 1/2" SOC		
6/32 x 1/2" SOC		
<b>METRIC</b>	.99	3mm x 12mm
3mm x 20mm		
3.5mm x 12mm		
3.5mm x 20mm		
4mm x 12mm		
4mm x 20mm		
5mm x 16mm		
6mm x 16mm		